



www.essarairsystems.com

An ISO 9001 : 2008 Certified Company

ABOUT US

ESSAR ENVIRO AIR SYSTEMS has been in the business of Air pollution control equipment and Material Handling Equipment since 2007. Our standards of air pollution control systems in terms of air emission, efficiency & power demand are in line or better than industry norms. Our Material Handling Equipment are in Operation in Industry like Cement, Steel, Fertilizer etc..., We utilise most innovative and state of art technology in all our equipment manufacture and offer our customer a total solution rather than mere supply.

We have R&D facility for specific to customer need. We have experienced Engineers in Design, Manufacturing & Erection. ESSAR team is a qualified and experienced in the technocrat and entrepreneur. We have modern facility of Manufacture for the fabrication, Machining, Assembly and testing. we have a tight quality control system. we offer onestop solution to our customer. ESSAR getting repeat orders for our all over India customers, which is a proof of our quality and reliability. We also executed export orders.

We also **ISO 9001:2008 Certified Company**



Mission

Mission way of thinking philosophy, what we live for... call it what you want you'll find it below. Introduce yourself to the way we think.

"To TRANSFORM our spheres of influence and to improve the quality of life by building institutions that provide better ACCESS to better dust & pollution free services to more people ..all the time".

We aim at supplying the best products in the markets that give maximum satisfaction to our clients and help in keeping the environment clean.

Vislon

To develop energy efficient systems by doing equipments continous research & development. By keeping in the view of end user requirement. fThe ESSAR ENVIRO AIR SYSTEMS design, manufacture and supply at affordable cost with high features.

Our Products

Air Pollution Control Equipments

- * DUST COLLECTOR (PULSE JET BAG FILTERS)
- * CENTRIFUGAL BLOWERS
- * FUME EXTRACTION SYSTEMS
- * CYCLONE SEPARATORS
- * MULTY CYCLONE SEPARATORS
- * SCRUBBERS

Material Handling Equipments

- * SCREW CONVEYORS
- * BELT CONVEYORS
- * BUCKET ELEVATORS
- * ROTARY AIR LOCK VALVES
- * AIR SLIDES



BUCKET ELEVATORS

Essar has established a leading position in design and supply of bucket elevators to various industries. Bucket elevators for mechanical, vertical transportation of materials have become crucial link in production process in many industrial sectors.

Elevators supplied by ESSAR are working satisfactorily with more than rated capacity, optimum power consumption.

Bucket & Casing sizes are as per Indian standards. Large number of satisfied customers give evidence of fact that ESSAR Elevators are Economical, efficient & almost maintenance free. MS, SS & Plastic buckets are offered as required by customer, along with belt/chain are also offered to food & fertiliser & chemical industries.



Product range

- * 1-30 meters shaft C/C distance
- * 1 TPH - 350 TPH
- * Ambient to 250 c
- * Powder materials, grains, Hot material applications

Sallent Features

- * Continuous or centrifugal discharge
- * Rigid strong built casings in perfect alignment and weather tight
- * Two piece hood, permitting access to head section interior, without disturbing machinery
- * Inspection covers that can be easily lifted to view terminal machinery
- * Large latch type door located in front/back/sides of boot section to facilitate inspection, service and clean out
- * The head shaft is mounted in antifriction bearings, pillow blocks
- * Superior components, chain, sprockets, pullers, belt buckets & bearing take up & drives
- * Hold back device to prevent reverse motion of buckets.

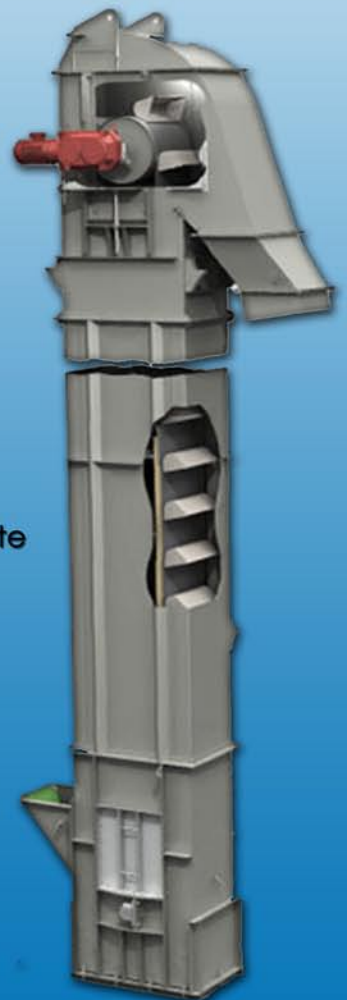

Construction and Components of Bucket Elevators

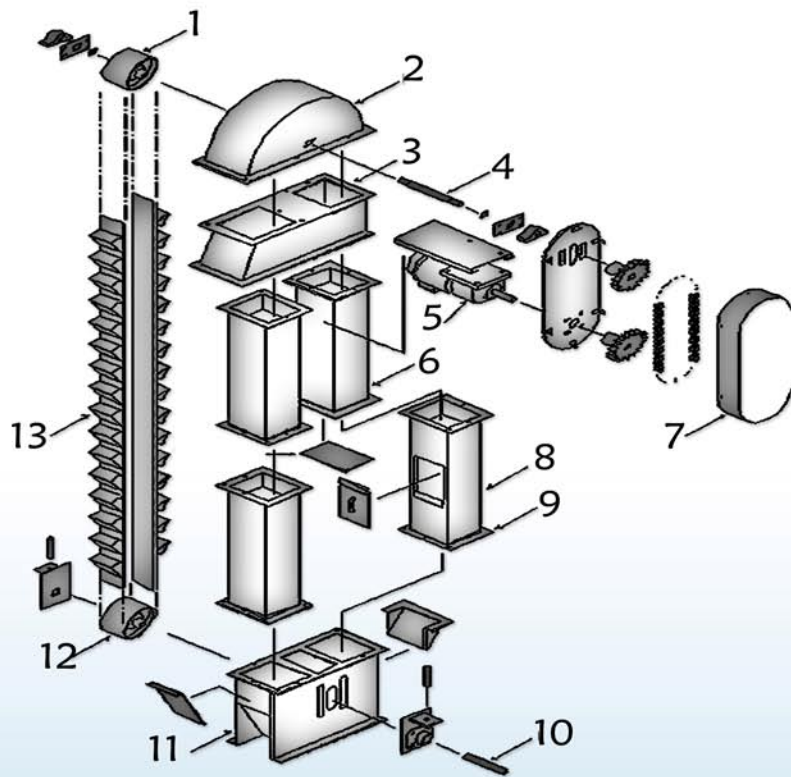

- 1 - head pulley
- 2 - head cover
- 3 - head
- 4 - head shaft
- 5 - drive motors
- 6 - legging
- 7 - chaincase
- 8 - inspection leg
- 9 - flange
- 10 - boot shaft
- 11 - boot
- 12 - boot pulley
- 13 - bucket

Type of Bucket Elevators

Type of Discharge

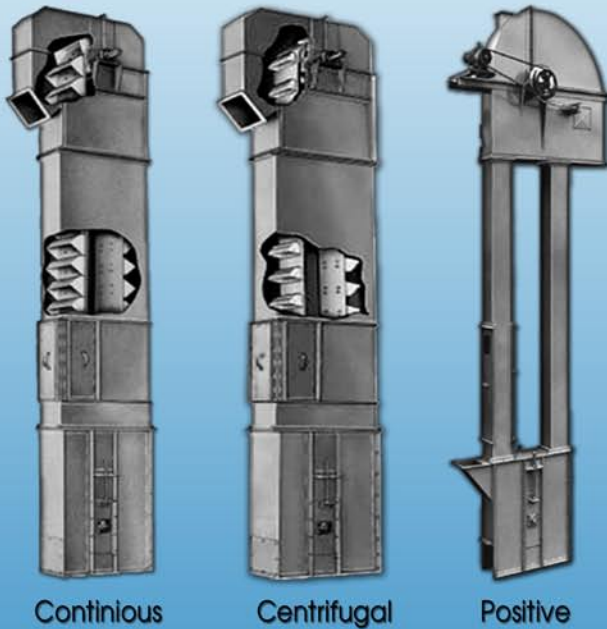

Continuous

Centrifugal

Positive

Spare Parts

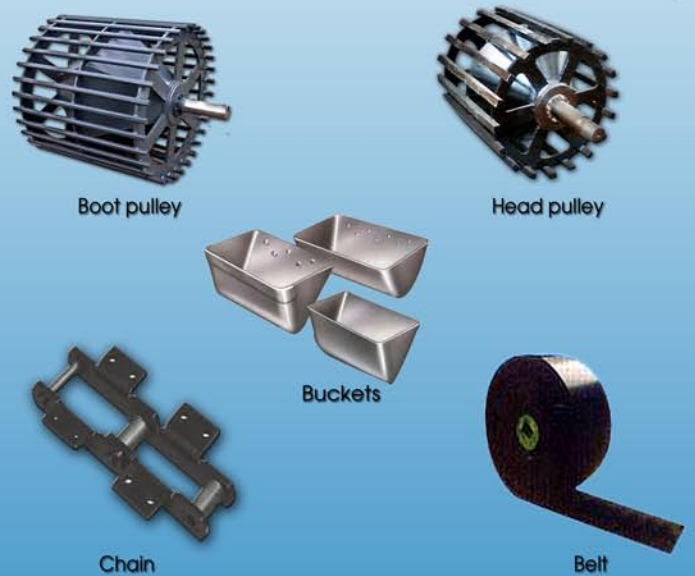

Boot pulley

Head pulley

Buckets

Chain

Belt

Applications

- * Cement plants
- * Power plant
- * Sponge Iron/Steel plants
- * Chemical Plant
- * Food Industry
- * Plastic Industry
- * Foundries
- * Ceramic Industry
- * Rubber Industry
- * Wood Industry
- * Glass Industry
- * Pesticides Industry

ESSAR
ENVIRO AIR SYSTEMS

Plot No.10c, Phase-IV, I.D.A.,
 Jeedimetla, Hyderabad-500 055,
 Andhra Pradesh, India.

Office : 040-20000730,
 Tele Fax : 040-42204348,
 CELL : 9866583700,9652883700
 Email : essareng777@gmail.com
 info@essarairsystems.com
 Website : www.essarairsystems.com



POLLUTION CONTROL SOLUTIONS

An ISO 9001:2008 Certified Company